



OPERATING MANUAL
MINIRATOR MR2 / MR-PRO

Contact NTi Audio at

Headquarter	☎ +423 239 6060	✉ info@nti-audio.com
Americas	+1 503 684 7050	americas@nti-audio.com
China	+86 512 6802 0075	china@nti-audio.com
Czech	+420 2209 99992	czech@nti-audio.com
France	+33 4 78 64 15 68	france@nti-audio.com
Germany	+49 201 6470 1900	de@nti-audio.com
Japan	+81 3 3634 6110	japan@nti-audio.com
South Korea	+82 2 6404 4978	korea@nti-audio.com
United Kingdom	+44 1438 870632	uk@nti-audio.com

www.nti-audio.com



NTi Audio AG
Im alten Riet 102, 9494 Schaan
Liechtenstein, Europe

is an ISO 9001:2015 certified company.

© All rights reserved.
All information subject to change without notice
Firmware MR2 2.16, MR-PRO 2.16
Version Jul 2021

®
TM Minirator and Minilyzer are registered trademarks of NTi Audio.
XL2, Exel, Acoustilyzer, MiniSPL and MiniLINK are trademarks of NTi Audio.

Made in
Switzerland



Table of Contents

1. Basics	4	Chirp	28
Introduction.....	4	Delay Test.....	29
Scope of Delivery	4	Pink Noise.....	30
Notes	5	White Noise.....	31
Accessories	6	Polarity.....	31
2. Overview	7	Wave File Player (MR-PRO only).....	32
Connections.....	7	6. Measurement Functions	35
Buttons and Operating Elements.....	8	Impedance Test in Generator Mode.....	35
Screen Display.....	9	Balance Display.....	36
Power Supply.....	11	Measuring Phantom Power Voltages	37
Characteristics of the Outputs.....	12	XLR Cable Test.....	38
3. Getting Started	14	Impedance Test.....	40
Inserting the Batteries	14	7. Taking a Screenshot	42
Fitting the Protective Shock Jacket (MR-PRO only)	15	8. Updating the Firmware	43
Attaching the Hand Strap.....	16	9. Tips and Troubleshooting	44
Connecting the Minirator	17	Resetting to the Factory Settings	44
4. Operation	18	Reloading WAV-files (MR-PRO only)	44
Switching the Minirator on and off.....	18	Behavior with low-impedance Loads	44
Navigation in the Menu Bar	18	PC recognizes Minirator as GPS Camera.....	44
Selecting a Test Signal	19	Faults and their Correction.....	45
Setting the Parameters.....	20	10. Further Information	46
Setting the Sensitivity of the Rotary Wheel.....	21	My NTi Audio	46
System Settings.....	22	Warranty Conditions	47
Configurations (MR-PRO only).....	24	Calibration Certificate.....	47
5. Test Signals	26	Service and Repairs	47
Sine.....	26	Declaration of Conformity.....	48
Sweep.....	26	11. Technical Data Minirator	49

1. Basics

Introduction

Thank you for purchasing the Minirator. The Minirator is a powerful audio generator, offering a wide range of analog test signals for the calibration, maintenance and repair of professional audio systems.

The rotary wheel combined with surrounding fast access function keys enables instant and intuitive operation without compromising fine adjustment capabilities.

While the MR2 has been optimized for “Value at a most attractive price”, the MR-PRO has been developed with additional innovative functionality for even more demanding applications.

The MR-PRO is also equipped with the following functions:

- Integrated measurement functions for impedance, balance and phantom power voltages
- Playback of WAV-files
- Cable tester
- Impedance test of distributed 70V/100V speaker systems

Scope of Delivery

The following items are included with the respective model:

MR2:

- MR2
- Operating manual
- USB cable
- Hand strap

MR-PRO:

- MR-PRO
- Protective shock jacket
- Operating manual
- USB cable
- Hand strap

Notes

**Danger of electric shock**

Never connect the instrument to a power output!

Non-compliance could result in damage to persons or property that is not covered by the warranty.

**Damage caused by opening the instrument**

Never open the instrument.

The instrument can be damaged if the housing is opened, and your warranty will be invalid.

**Damage through damp**

Do not use the instrument in damp environments!

The instrument can be permanently damaged by the penetration of water.

Accessories

Accessories available for the MR2 / MR-PRO:

- Pouch MR2 / MR-PRO NTi Audio # 600 000 302

The soft pouch protects the Minirator against shock and dust and comes with a convenient belt-clip.

- Exel System Case NTi Audio # 600 000 334

This compact system case provides the professional transport protection for work in the field. It offers space for the handheld instruments, cables and connectors.

- Mains Power Adapter NTi Audio # 600 000 333

Mains Power Adapter with removable plug types. The Mains Power Adapter suits the typical power sockets in Australia, China, Europe, Japan, US and UK.

- Minirator -40dB Adapter NTi Audio # 600 000 312

Attenuator for high quality microphone level signals.

- Cable Test Adapter NTi Audio # 600 000 311

The Cable Test Adapter is used for single-ended cable testing. By installing the Cable Test Adapter at the far end of the cable, the MR-PRO will be able to complete its cable test procedure and display the condition.

- 70V/100V Protection MR-PRO NTi Audio # 600 000 313

Protects Minirator MR-PRO against accidentally applied 70V/100V voltages during impedance or power testing at distributed speaker systems.

- Calibration Certificate NTi Audio # 600 000 018

Individual calibration certificate with serial number, traceable according to the ISO/IEC 17025 standard. Calibration certificates for new products have to be ordered together with the product. After the purchase we recommend the annual calibration of the instrument.

2. Overview

Connections

The Minirator has the following connections:

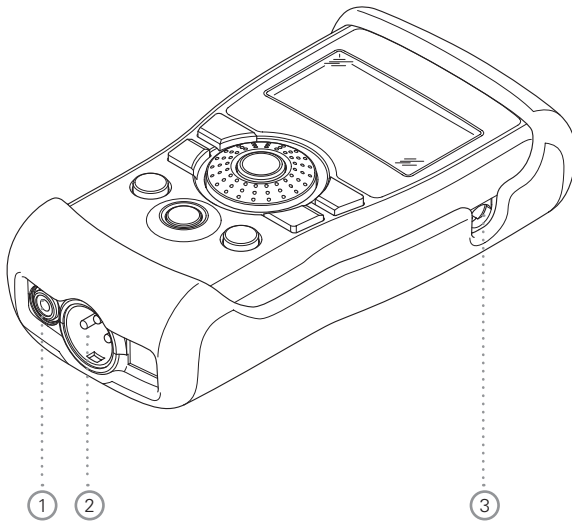

- ① RCA output (unbalanced)
- ② XLR output (balanced)
- ③ DC power socket

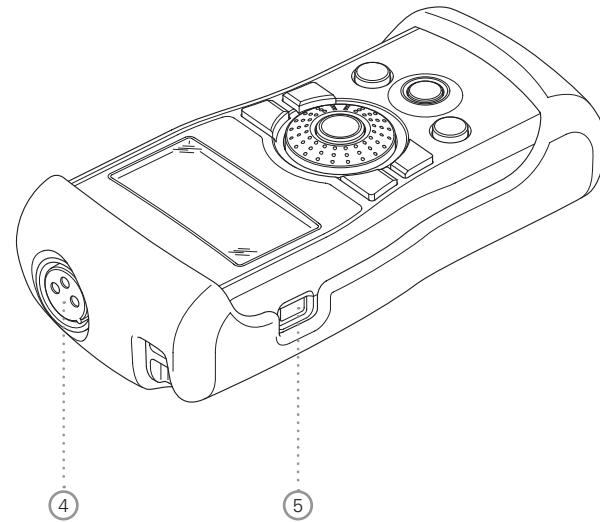

- ④ XLR input for the cable test
(MR-PRO only)
- ⑤ USB connection (Mini-B, 5 pin)

Buttons and Operating Elements

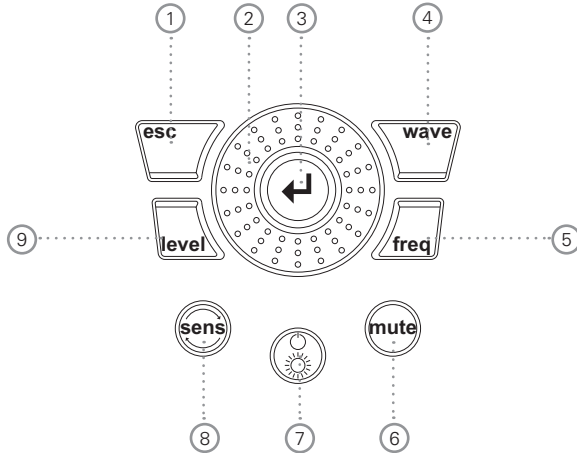

- ① ESC Terminates an entry, jumps to the top menu level or closes an open window.
- ② Rotary wheel
Slow turning: Precise setting of the value.
Rapid turning: Setting the value in larger steps.
- ③ Enter Confirming a selection.

- ④ Wave Selection of the test signal.
- ⑤ Freq Setting the output frequency. Direct jump to the "PARAM" menu with the "SWEEP" and "CHIRP" test signals.
- ⑥ Mute Switches off the output signal. Mute is indicated at the lower right corner of the display and a flashing mute button.

The button lights up continually during the pauses of the "PNoise" and "Chirp" signal waveforms.

- ⑦ On/Off Switches the instrument off if held down for one second. Switches the back-lighting on and off.
- ⑧ Sens Changes the sensitivity steps of the frequency and level settings.
- ⑨ Level Setting the output level. You can set up the output signal in the following units: dBV, dBu,V. With the MR-PRO, dBF (dB referred to Full Scale) and % units are available when playing back Wave files.

Screen Display

Main Menu

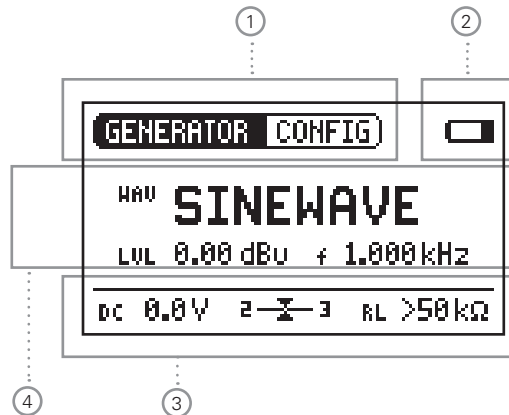

- ① Menu bar
- ② Battery symbol:
If the battery symbol lights up the batteries are almost completely discharged and must be replaced.
- ③ Display of the readings (MR-PRO)
- ④ Settings for signal generation

Settings for Signal Generation

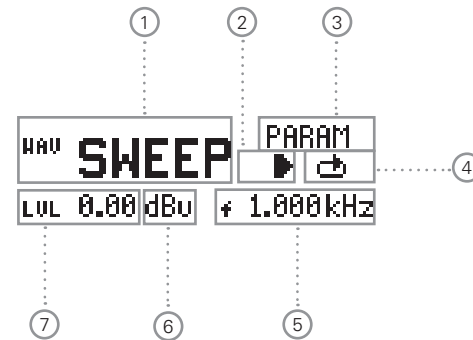

- ① Test signal
- ② Start / Stop for certain test signals
- ③ Setting up the parameters
- ④ Single / continuous mode for certain test signals
- ⑤ Output frequency
- ⑥ Units for the output level
- ⑦ Output level

Display of the Measured Values (MR-PRO)

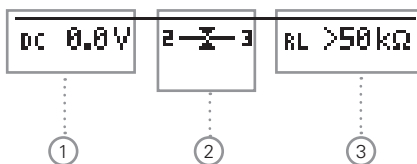

- ① Phantom voltage
- ② Balance
- ③ Impedance

Taking a Screenshot

A screenshot may be stored in the Minirator MR-PRO memory for documentation of the generator settings or the measurement results. Follow these steps:

- Connect the Minirator MR-PRO to the computer.
- Create a new folder "Screen" in the MR-PRO memory.
- Remove the instrument from the computer.
- Power on the Minirator MR-PRO.
- Adjust the required settings or perform a measurement.
- Press the On/Off button and the Enter-button at the same time shortly.

The screenshot has been stored in the MR-PRO memory.

Power Supply



Battery Operation

In order to be always able to use the Minirator flexibly, we recommend the use of batteries.

	<ul style="list-style-type: none"> • Only use 3x AA, LR6 batteries. • The battery consumption increases at higher level setting as well is based on the connected load. • During operation, the battery temperature may increase noticeably. This is not a defect. • The instrument can also be used with rechargeable batteries.
---	---

Operation using the mains power supply

You can also connect the Minirator to a mains socket with a DC power supply unit, which is available for order at NTi Audio. We recommend remaining the batteries inside the instrument.

	<p>We recommend using the NTi Audio mains power adapter. This is a switching power supply and leads to increased noise at the unbalanced output connector.</p> <p>Alternatively you may utilize a linear power supply adapter with EU-connector for unbalanced signal applications. NTi Audio # 600 000 305.</p> <p>In case you want to make use of a different DC power supply unit, you must observe the following specifications:</p> <ul style="list-style-type: none"> • electrically-isolated, non-earthed linear DC power supply unit • 2.1 x 5.5 x 9.5 mm plug • connection +  - • Voltage from 5 to 9 volts and a current of at least 500 mA. <p>Damage caused by using an inappropriate external DC supply is not covered by warranty.</p>
---	---

Characteristics of the Outputs

The Minirator has two outputs that are wired in parallel: An unbalanced RCA output and a balanced, non-earthed XLR output. Both outputs are resistant to externally applied phantom power. Wherever possible, always use balanced (XLR) connections, as these have much better immunity to interference than unbalanced connections.



Do not use both outputs at the same time.

The simultaneous use of both outputs could lead to a short-circuit in one of the generator outputs in the connected instrument.

Allocation of the XLR Output:

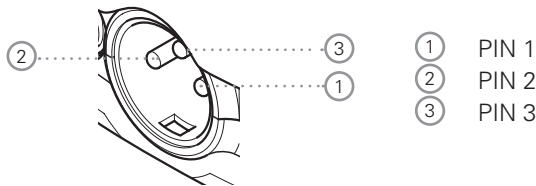

MR2 Outputs

Both the RCA and the XLR have a balanced output impedance of 200 Ohm.



The voltage at the MR2 XLR or RCA output is less than the set voltage U with low impedance loads.

Example:

A balanced 200 Ohm load impedance matching the 200 ohm output impedance will result in the expected output drop of 6 dB.

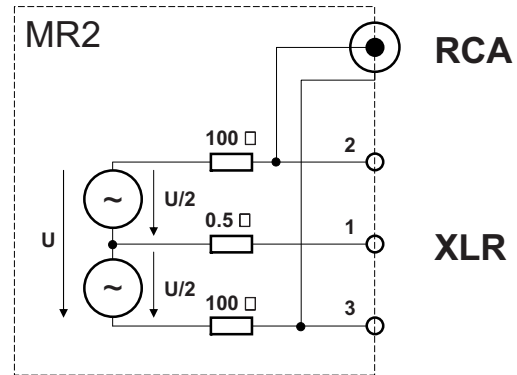

MR-PRO Outputs

Both the RCA and the XLR have a balanced output impedance of only 12.5 ohms. The level of the XLR output corresponds closely to the set output voltage, based upon the low 12.5 ohm output impedance of the generator.

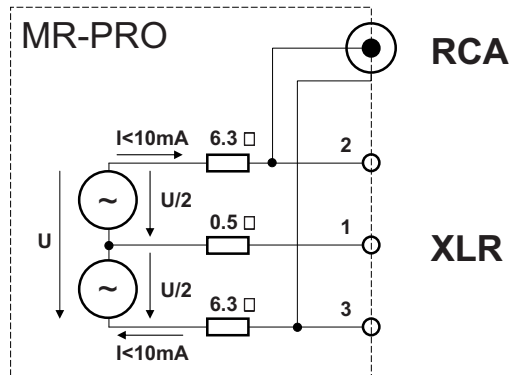

Behavior with low-impedance Loads

The maximum output current of the MR-PRO is 10 mA. If the connected load consumes more current, the internal regulation of the MR-PRO reduces the output level. This condition will be indicated on the screen by the flashing output level display:

LVL 0.00 dBu .



XLR short-circuit between Pin 1 and 3

Commercially available XLR to RCA adapters short-circuit the XLR Pins 1 and 3. Do not use such adapters with the Minimator! They will reduce the signal quality, thus use the RCA output instead.



The MR-PRO is designed for loads down to 600 Ohm. Depending on the output level and the output frequency, however, the level is maintained, even for lower load impedances.



Minimator -40dB Adapter

For highest quality microphone level signals we recommend the "Minimator -40dB Attenuator" which is available as an accessory. It improves the signal to noise ratio for low level signals by 40 dB.

NTi Audio # 600 000 312

3. Getting Started

Inserting the Batteries



- Only use batteries from the same manufacturer.
- Replace the discharged batteries by new ones.
- Do not mix used and new batteries.

- Open the battery cover.
- Insert three AA-LR6 batteries with the same state of charge, paying attention to the +/- marking in the battery compartment.
- Close the battery cover once the batteries have been inserted.

👉 You have now successfully inserted the batteries.

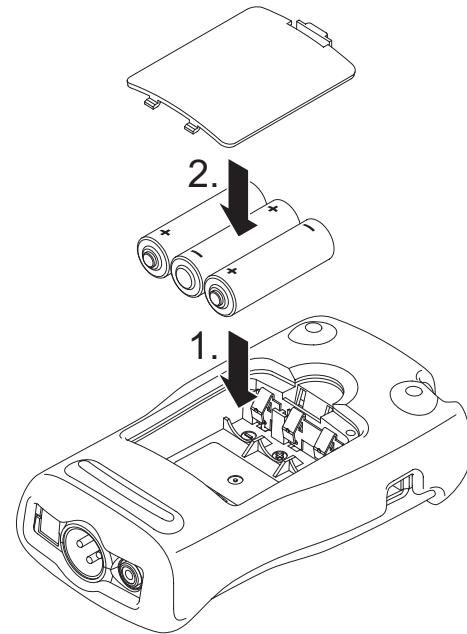

Fitting the Protective Shock Jacket (MR-PRO only)

With the MR-PRO, you can fit the supplied protective shock jacket. This will protect the instrument against light impacts without impairing its easy operation.

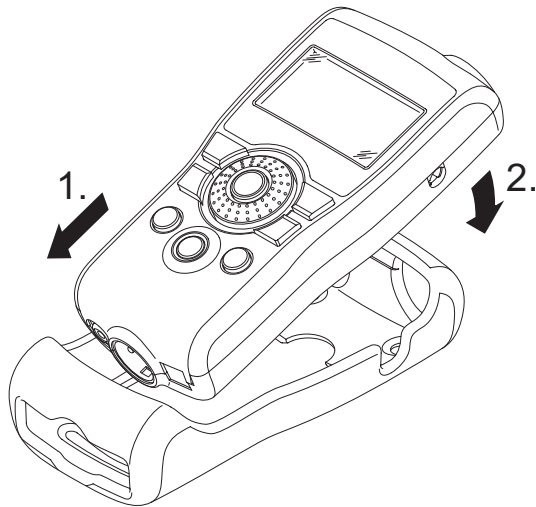

- Push the lower end of your MR-PRO into the lower end of the protective shock jacket.
- Push the upper end of the MR-PRO into the protective housing.

 You have now fitted the protective shock jacket



Damage through impacts / shocks

- The protective shock jacket shields your MR-PRO against reasonable impacts that could occur in normal use.
- But do not intentionally subject the instrument to extreme stress!
- Please do not drop the instrument!
- Damage caused by dropping or impact is not covered by warranty.

Attaching the Hand Strap

To prevent you from accidentally dropping the Minirator, a hand strap is supplied with the instrument. You can also fit the hand strap when the protective shock jacket of the MR-PRO has been fitted.

- Pull the hand strap through the opening.
- Pull the rear part of the hand strap through the loop of the front part.
- Pull the hand strap tight.

👍 You have now secured the hand strap.

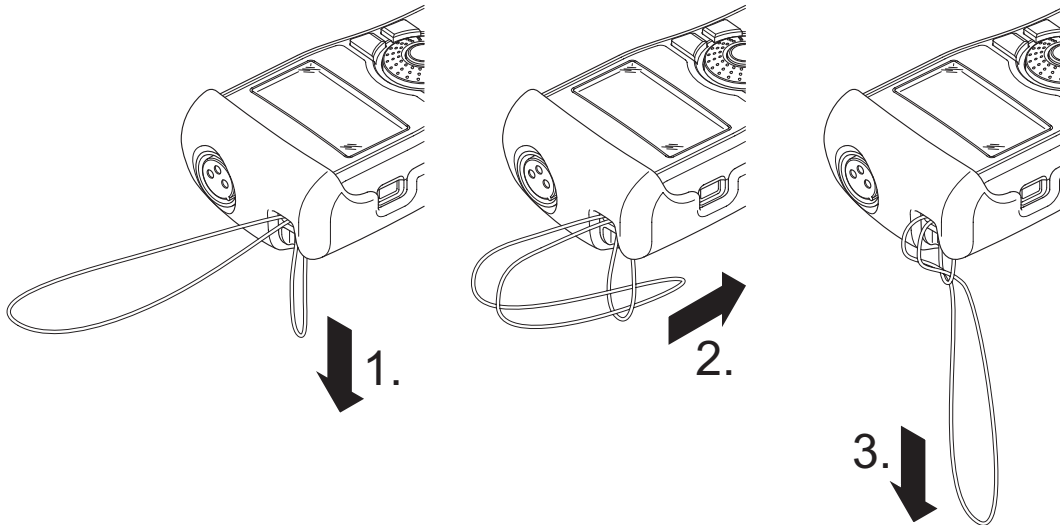

Connecting the Minirator

XLR Connection

- Connect the Minirator to your audio device using an XLR cable. Note that the locking pin of the plug must be located on the lower side of the instrument!

👍 You have now connected the Minirator.

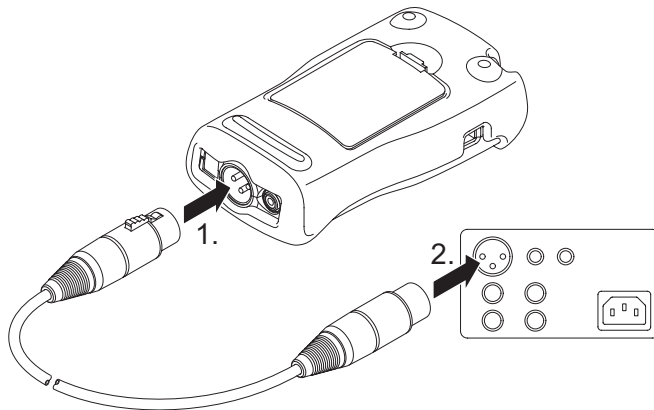

RCA Connection

- Connect the Minirator to the input of the unit to be tested using a RCA cable.

👍 You have now connected the Minirator.

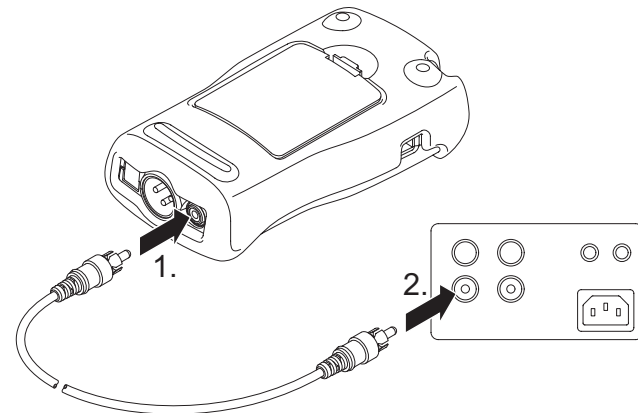

4. Operation

Switching the Minirator on and off

Switching the Minirator on

- To switch the Minirator on, press the “On/Off” button.
- 👍 The display lighting is switched on.
You have switched on the Minirator.

Switching the Minirator off

- To switch the Minirator off, press the “On/Off” button and hold it down for one second.
- 👍 You have switched off the Minirator.

Navigation in the Menu Bar

The menu bar is divided into two parts. On the left-hand side, you can choose between the Generator, Cable test (MR-PRO only), Impedance (MR-PRO only) and System functions.



- To do this, select the left side of the menu bar with the rotary wheel and confirm with “Enter”.
- 👍 A selection window opens.
- Select the desired function with the rotary wheel.
- Confirm the selection with “Enter”.
- 👍 You have now selected the desired function.

You can save and call up configurations on the right-hand side of the menu bar (see the “Configurations” chapter, MR-PRO only).

Selecting a Test Signal

You have two choices for selecting test signals. You can use either the direct buttons or the rotary wheel.

Signal selection using the direct buttons

- Ensure that GENERATOR **1** is selected in the menu bar.
- Press the “Wave” button.

A selection menu appears.

- Select the desired test signal with the rotary wheel.
- Press “Enter”.

You have now selected the test signal.

Signal selection using the rotary wheel

- Ensure that GENERATOR **1** is selected in the menu bar.
- Select “WAV” **2** with the rotary wheel.
- Press “Enter”.

A selection menu appears.

- Select the desired test signal with the rotary wheel.
- Press “Enter”.



You have now selected the test signal.

Setting the Parameters

You have two possibilities for setting up the parameters for the test signals. You can use either the direct buttons or the rotary wheel.

Setting parameters using the direct buttons

- Press the “Level” or “Freq” button.

👍 You have selected the desired parameter.

- Turn the rotary wheel to set the parameter.
- Confirm the setting with the “Enter” button.

👍 You have now set up the parameter.

Setting parameters using the rotary wheel

- Turn the rotary wheel.

👍 The selected parameters will be marked with a black bar.



- Confirm your choice with the “Enter” button.

👍 The parameter display blinks.

- Turn the rotary wheel to set the parameter.
- Confirm the setting with the “Enter” button.

👍 You have now set the parameter.

Setting the Sensitivity of the Rotary Wheel

You can set up the sensitivity (step size) of the rotary wheel. To do this, proceed as follows:

- Select Level **LVL** or Frequency **f** with the rotary wheel.
- Hold down the “Sens” button.

👍 The current sensitivity of the rotary wheel will be displayed **1**.

- Turn the rotary wheel to set up the desired sensitivity.
- Release the “Sens” button to accept the desired sensitivity.

👍 You have now changed the sensitivity of the rotary wheel.

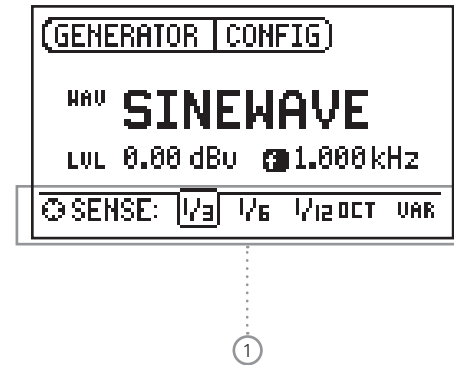

System Settings

You can adjust various system settings of your instrument. To do this, switch to System ① in the menu bar using the rotary wheel and confirm with “Enter”.

The possible system settings are displayed:

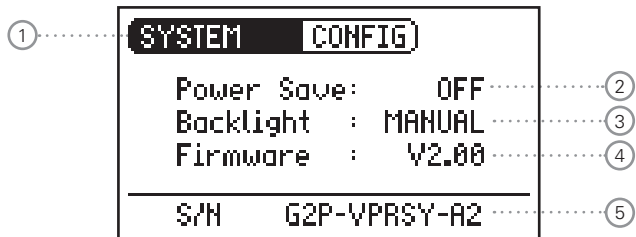

Power Save

The Power Save mode switches the instrument off if no button has been pressed within an adjustable time period.

- Use the rotary wheel to select the Power Save function ②
- Confirm the selection with the “Enter” button.

👉 The display starts to blink.

- Turn the rotary wheel to set the desired time.
- Confirm the entry with the “Enter” button.

👉 You have now changed the switch-on time of the Power-Save mode.

Backlight

You can choose between “Auto” and “Manual”.

Auto The backlight will be switched on automatically during operation, and will be switched off again after a period of time.

Manual Press the “On/Off” button to switch the background lighting on and off.

- To do this, select the Backlight ③ function with the rotary wheel.
- Press “Enter”.

 The display now changes between “Auto” and “Manual”.

Firmware

Display of the version number, with the possibility of carrying out an update for the MR-PRO ④ (see chapter “Updating the Firmware”).

Display of the Serial Number

You can read out the instrument’s serial number ⑤ from the bottom line.

Setting the Contrast

Changing the contrast of the screen display.

To do this, proceed as follows:

- Hold down the “ESC” button and turn the rotary wheel until the desired contrast is obtained.

 You have now changed the contrast of the screen display.

Configurations (MR-PRO only)

With the MR-PRO, you can store your current instrument settings as configurations, and can call these up again at a later date.

Storing configurations

10 configuration storage locations are available to you.

- Using the rotary wheel, select CONFIG in the menu bar.
- Confirm with "Enter".

👉 The following menu is opened:



- Select STORE and confirm with "Enter".

👉 The following selection menu is opened:



- Select a memory location with the rotary wheel and store your configuration by confirming the selection with "Enter".

👉 You have now stored the current instrument settings as a configuration.



In order to easily remember configurations you may rename them.

For altering the file names, connect the MR-PRO to a computer via USB and rename the files in the CONFIG folder. Only the first 10 configurations are shown in the display.

Calling up Configurations

- Use the rotary wheel to select CONFIG in the menu bar.
- Confirm with “Enter”.

👍 The following menu is opened:



- Select “Recall” and confirm with “Enter”.
- Select the desired configuration in the Selection menu and confirm with “Enter”.

👍 You have now loaded the desired configuration.

Transferring Configurations to another Device (MR-PRO)

With the MR-PRO, you have the possibility of transferring stored configurations to another device.

- Connect your MR-PRO to a computer via USB.

👍 A removable memory drive will be indicated on the computer.

- Select the CONFIG sub-folder.

👍 You will see the stored configurations of your MR-PRO.

- Copy this data to your computer.
- Connect another MR-PRO to the computer via USB.
- Copy the previously copied data into the CONFIG sub-folder by overwriting the data therein.

👍 You have now transferred configurations from your MR-PRO to another MR-PRO.

5. Test Signals

Sine

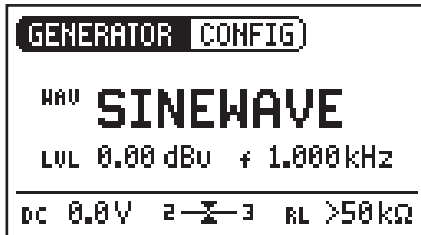

Characteristics and use

Pure sinusoidal signals are required for almost every audio measurement. The Minirator provides a wide and adjustable output level range and selectable output frequencies.

Parameters

- LVL** Output level
- f** Output frequency



Sweep



Characteristics and use



Sweep signals with a resolution of up to 1/12 octave can be generated over a freely selectable frequency range. An audio analyzer like the Minilyzer from NTi Audio can automatically trigger to this signal sequence to measure the frequency response.

Starting the Sweep Signal

- Select the "START" symbol  with the rotary wheel.
-  You can interrupt a running sweep via the „STOP“  symbol.

Sweep Signal Modes

Using the “MODE” symbol, you can run the test signal in the following modes:

- Once-only  Plays the test signal once
- Continuous  Repeats the test signal after an adjustable pause (t_{PAUSE}).

Parameters

- LVL** Output level
- f** The frequency display is for information only. The current frequencies will be displayed here once the SWEEP test signal has been started.
- PARAM** You can configure the signal sequence here.

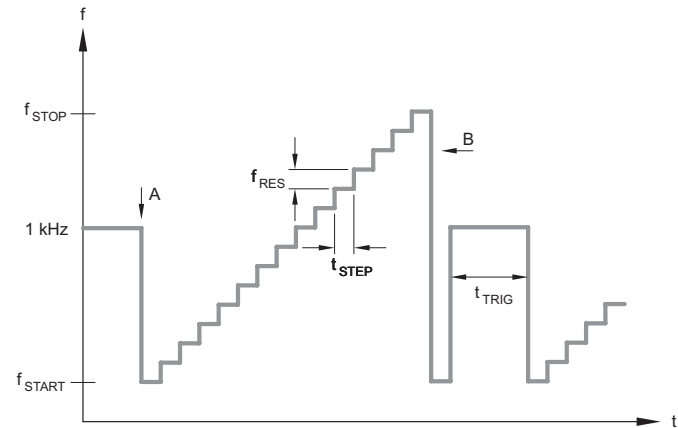

- A The sweep recording starts as soon as the frequency drops from 1 kHz to f_{START} .
- B The end of the sweep will be signaled by a falling frequency.

Chirp





Characteristics and use

A Chirp is the name for a signal whose frequency continually changes over time (also known as continuous sweep). It is used for the recording of frequency responses, the measurement of impulse responses and the acoustic assessment of rooms.



Starting the Chirp signal

- Select the START  symbol with the rotary wheel.

 If this is activated, it turns into a STOP symbol , which will end the test signal when selected.

Chirp Signal modes

Using the “MODE” symbol, you can run the test signal in the following modes:

- Once-only  Plays the test signal once
- Continuous  Repeats the test signal after an adjustable pause (tPAUSE).

Parameters

- LVL** Output level
- f** The frequency display is for information only. The current frequencies will be displayed here once the CHIRP test signal has been started.
- PARAM** You can configure the signal sequence here.

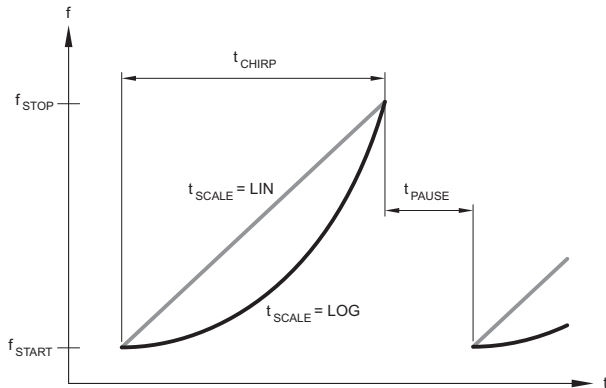

Fading in and out of any Chirp signal generates spurious frequency components, leading to ripple in the frequency response.

The Chirp sequences of the MR-PRO / MR2 are optimized for ripple of ± 0.2 dB maximum. Parameter combinations resulting higher ripple are automatically corrected during input.

Delay Test

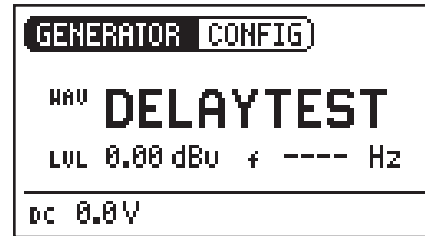

Characteristics and use

The Delay Test signal is a specially configured Chirp signal. It enables to setup delay lines in combination with the NTi Audio Acoustic Analyzers. You can find further information in the application notes and user manuals of acoustic analyzers.

Parameters

LVL Output level

White Noise



Characteristics and use

The White Noise test signal has a high spectral density, Gaussian amplitude distribution and an infinite period (> 100 years). White Noise is used for all measurements with FFT analyzers, and has a constant signal power per Hertz and a 20 kHz bandwidth.

Parameters

LVL Output level

Polarity



Characteristics and use

The sawtooth test signal is ideally suited for checking the polarity of loudspeakers. The NTi Audio analyzers detect this signal and determine the polarity.

Parameters

LVL Output level

f The frequency display is for information only. The frequency cannot be adjusted.

Wave File Player (MR-PRO only)



Characteristics and use

You can play back your own test sequences with the MR-PRO. The test sequences will be repeated automatically and without pauses. For a better overview, Wave files are organized in sub-folders.

The MR-PRO is already equipped with a series of demo sequences in the WAV file format. You can create a link to a computer at any time via the USB interface and can exchange existing wav-files or add new ones.

Possible applications

Possible applications include, for example:

- Identification generator in the broadcasting sector
- Musical signals for the assessment of PA systems
- Playing back complex test signals

Selecting a folder

- Select the Symbol folder ① with the rotary wheel.
- Confirm with “Enter”.
- Select the desired folder with the rotary wheel.
- Confirm with “Enter”.

👉 You have now changed the current playback folder.

Selecting a Wave file

- Use the rotary wheel to select the Symbol file ②.
- Confirm with “Enter”.
- Select the desired WAV file with the rotary wheel.
- Confirm with “Enter”.

👉 The wav-file will be played.

Default WAV-files

The factory default wav-files are

- **Ansagen:** Anpassen (German)
Testsequenz (German)
- **Messages:** Adjust (English)
Occupied (English)
Test sequence (English)
- **Signals:** Fast Pink Noise 1s
Fast Pink Noise 4s
NTi Audio STIPA
- **Sounds:** Drum1
Drums2
Hihat
Sax
Synth1

Further customized wav-files are available for download on the Minirator support page at "<https://my.nti-audio.com>".



Copyright

NTi Audio delivers a set of wave files with the MR-PRO. These wave files may only be replayed with an NTi Audio instrument (MR-PRO). Any further usage is forbidden.

Loading your own wav-files

Wave files for the MR-PRO must fulfill the following requirements:

- 48 kHz sampling frequency
- Mono / Stereo
- 16 Bit resolution



If a wave file does not meet the requirements, the playback stops and the "Mute" button lights up continuously red. Wav-files can be converted to the above requirements by a free software available for download at www.nti-audio.com.

To load WAV-files, you will need a computer with the following minimum specifications:

- PC with Windows 98SE
- Macintosh computer with OSX

- Connect the MR-PRO to the computer via USB.



The MR-PRO appears on your computer as a removable data medium.



- All the sub-folders in the “Wave” folder now appear in the folder selection ①. Add additional sub-folders to this folder level as required.
- If necessary, you can make use of the other standard possibilities of a removable data medium. For example, you can copy wav-files from the MR-PRO onto your computer or delete unnecessary files.
- The absolute level generated at the output depends on the modulation as well as the signal form of the data present in the WAV file.
- Example: A fully modulated sinusoidal signal played back at 0 dBf generates an absolute level of 18 dBu at the output.

- Open the “WAVE” sub-folder on the removable medium
- Open one of the sub-folders in the “WAVE” folder.
- Copy the desired files into the folder.

You have now loaded your Wave files.

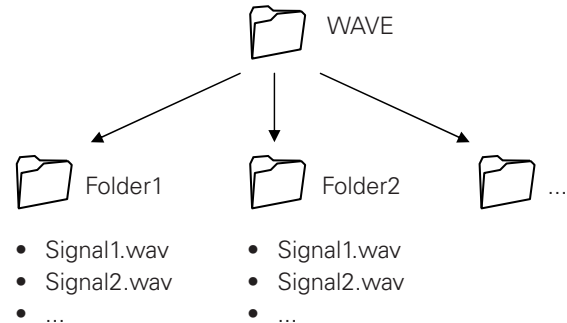

Parameters

- LVL** Output level
The output level of this test signal is adjusted in dBf (dB full scale) or %.

6. Measurement Functions

The MR-PRO offers the following measurement functions:

Menu	Measurements
Generator	Impedance Phantom Power Balance
Cabletest	XLR cables Phantom Power
Impedance	Impedance + Phase Apparent Power + Phase Phantom Power Balance



Impedance Test in Generator Mode

The MR-PRO measures phantom voltages and displays impedances and the impedance balance in the SINEWAVE operating mode. Using the SINEWAVE sinusoidal test signal, the MR-PRO measures the load connected to the output between PIN 2 and 3 ($RL=R2+R3$). The measured values of R2 and R3 will be displayed by selecting RL with the rotary wheel.

If only R2 or R3 can be measured, RL is replaced by R2 or R3 accordingly.



In the case of balanced connections (XLR), interference radiated onto the receiver side will be eliminated.

For this to work there must be a balanced impedance distribution on both signal lines. In the case of unbalanced impedance distribution, signal interference could occur. The MR-PRO allows you to test the connections for balance.

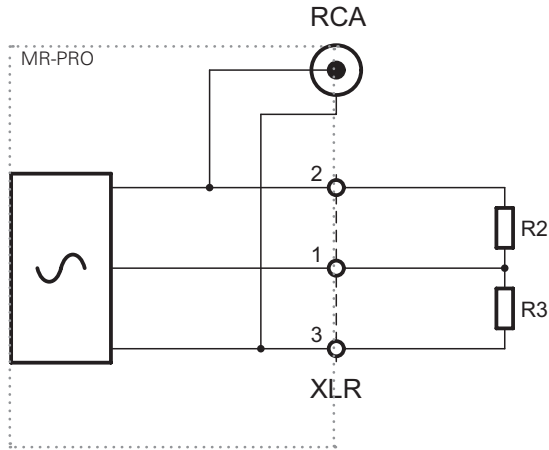

Balance Display

The balance display allows localizing a number of typical faults, such as short-circuits and defective cables.

In the case of an unbalanced impedance distribution, the display arrow points to the pin with the higher impedance.



Balanced impedance, $R2 = R3$



Unbalanced impedance, $R3 > R2$



The impedance and balance measurement can only be carried out down to a defined minimum level. If the measurement cannot be carried out, the display shows:



Unbalanced load relationships can be analyzed further by selecting the impedance display with the rotary wheel. If the impedance cannot be measured, the display shows “—” instead of the measurement value.

Measuring Phantom Power Voltages

The phantom voltage is necessary in connection with capacitor microphones in order to operate the impedance converter located in the microphone as well as for some "active" direct boxes.

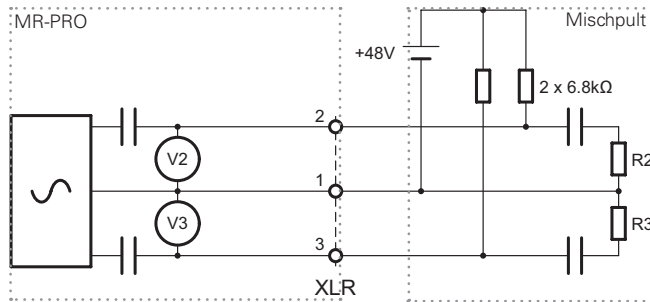

The most common phantom voltage is 48V and lies on both Pin 2 and Pin 3 with balanced impedances (see diagram).

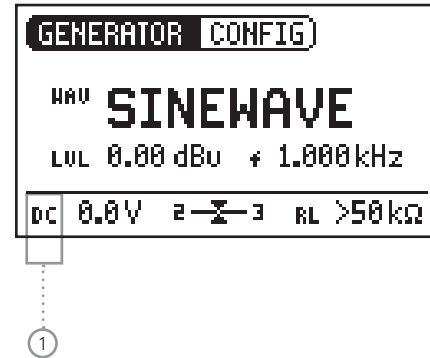

Unequal phantom voltages on Pin2 and Pin3 of the XLR cable indicate an error and will be displayed by the blinking of the phantom voltage display (DC).

You can localize the faulty voltage source by selecting the DC function ① with the rotary wheel.

XLR Cable Test

The MR-PRO supports a cable test function that quickly detects damaged XLR cables.

The cable test is based on an impedance measurement. In order to indicate a correctly wired XLR cable, the test routine of the MR-PRO assumes the following impedances on the output:

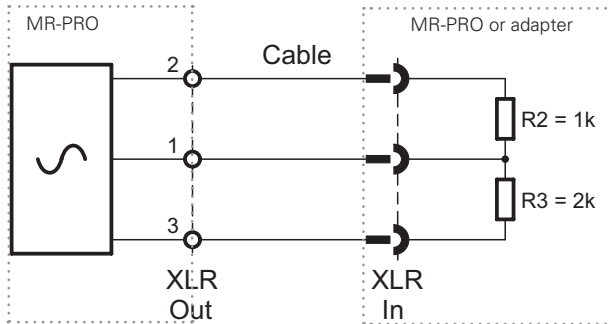

To test a cable, proceed as follows

- Select the "Cable test" function in the menu.
- Plug the XLR cable into the XLR output (1).
- Plug the other end into the XLR input (2).

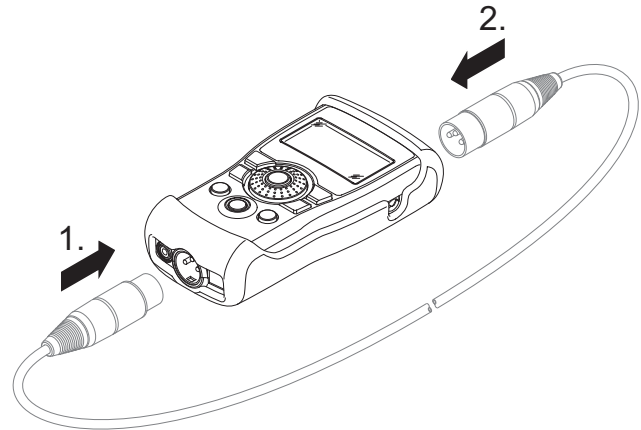

👉 The following is displayed on the screen:



The cable has not been plugged in correctly. Check the cable connection.

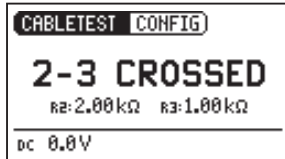

The tested cable is defective, the pins 2 and 3 are crossed. Other error indications may appear depending on the cables fault.



The tested cable is OK.



Cable Test Plug

For long cables already in place, NTi Audio offers an optional adapter named "Cable Test Plug". Plug one end of the cable into the Cable Test Plug and the other end of the cable into the MR-PRO.

Order information:

Cable Test Plug

NTi Audio # 600 000 311

Impedance Test

The impedance test supports the verifications of distributed loudspeaker installations and shows detailed information of the connected load.

Connect any unpowered load between Pin 2 and 3 of the XLR output for best performance.



Damage caused by high voltage

Never connect the instrument to a power output or any activated distributed speaker system!



70V/100V Protection for MR-PRO

Protects the Minirator MR-PRO against accidentally applied 70V/100V voltages during impedance or power testing at distributed speaker systems.

NTi Audio # 600 000 313

Display Modes

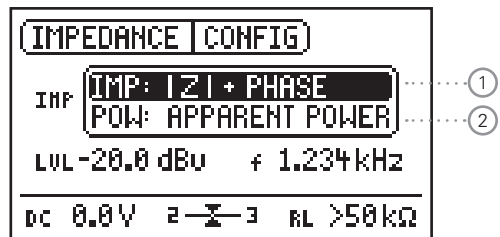

In the mode $|Z| + \text{Phase}$ ① the absolute value of the impedance and the phase is shown.

Based on the measured impedance, the apparent power ② which the load would sink when driven with a defined reference voltage is calculated and displayed.



Taking a Screenshot

A screenshot may be stored in the MR-PRO memory for documentation of the measurement results. See chapter "Screen Display" for details.

Impedance

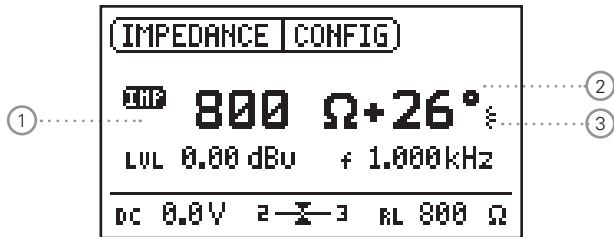

How to measure

- Connect the load between Pin 2 + 3 of the XLR.
- The absolute value of the impedance (1), the phase (2) and whether the load is inductive or capacitive (3) is displayed.

The output level and frequency may be adjusted as described earlier in this manual.

If the load is connected unbalanced (e.g. between pin 1 + 2), a "2" or "3" is displayed below the "IMP" symbol.

Power

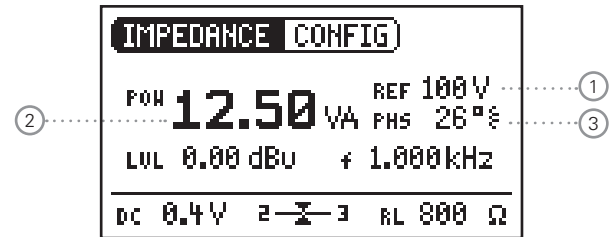

How to measure

- Select the reference voltage of the distributed loudspeaker system (1) with the rotary wheel.
- Connect the load between Pin 2 + 3 of the XLR.
- The apparent power (2) in VA (Volt Ampere) and the phase information (3) is displayed.

Selection of Phase / Power Factor readout

- Select "PHS" and press "Enter".
- The power factor PF = cos (phase angle) is displayed.
- Press "Enter" again.

👉 You have toggled between Phase and Power Factor display.

7. Taking a Screenshot

You may take a screenshot of the Minirator MR-PRO display and download it to your computer for reporting. Follow this instruction:

- Connect the Minirator MR-PRO via USB to the computer.

 The MR-PRO will show up as a drive on your computer.

- Create a new folder “Screen” in the root of Minirator drive.
- Disconnect the USB cable from the computer.
- Simultaneously press the On/Off button and the Enter button shortly on the Minirator MR-PRO.

 The MR-PRO screenshot has been saved in the folder “Screen”.

- Connect the Minirator MR-PRO via USB to the computer again.
- Download the screenshot for your reporting.

 Congratulations, you have taken a screenshot.

8. Updating the Firmware

You can find the installed firmware version of your instrument as follows:

- Select “System” in the menu bar.
- Confirm the selection with the “Enter” button.

 The firmware version of the instrument will be displayed.

The firmware update is carried out by connecting your Minirator to a computer via USB and running the PC application software “MR-Update”.



In order to update the firmware, you will need a computer with the following minimum specifications:

- PC with Microsoft Windows 2000 or newer
- USB termination
- Connection to web

Instructions:

1. When updating your Minirator for the first time

- Register your instrument at <https://my.nti-audio.com> (see chapter “Further information”). After the registration you will get the following details at the support page:
 - Firmware update instruction
 - Overview of new firmware features
- Download the software “MR_Up-date” at the Minirator support page.
- Install and run “MR_Up-date”
- Follow the instructions shown in “MR_Up-date”

2. If you have already updated your Minirator before

- Switch your computer online.
- Run the software “MR_Up-date”, which automatically checks the NTi Audio website for any new firmware available. No further manual download is required.
- Follow the instructions shown in “MR_Up-date”

 You have updated the Minirator firmware.

9. Tips and Troubleshooting

Resetting to the Factory Settings

If the Minirator reacts unexpectedly, a reset to the factory settings might solve the problem.

- Switch the instrument off.
- Hold down the “ESC” button and simultaneously operate the “On/Off” button.

 The confirmation of the reset is displayed on the screen.

Reloading WAV-files (MR-PRO only)

You can reload the wave files of the MR-PRO that were installed in the factory.

The files are available at the Minirator support page “<https://my.nti-audio.com>”.

Behavior with low-impedance Loads

The maximum output current of the MR-PRO is 10 mA. If the connected load consumes more current, the internal regulation of the MR-PRO reduces the output level. This condition will be indicated by a flashing output level display: LVL 0.00 dBu .

PC recognizes Minirator as GPS Camera

The MR-Update Software may not recognize the Minirator at PCs with Windows 7 installation.

- Open the device manager.
- Select with the right mouse button the GPS Camera driver, select “Properties” -> “Driver” -> “Update Driver”.
- Select „Search the compute for driver software“.
- Select “Select driver from list ...”.
- Select Minirator driver “atm6124.sys ATMEL AT91xxxx Test Board“.
- Complete the Minirator driver installation.

Faults and their Correction

Fault	Fault finding	Cause	Remedy
The Minirator does not generate an output signal.	"Mute" button blinks.	You have switched the instrument to Mute.	Press the "Mute" button.
	"Mute" button lights up continuously.	You have called up the "Pink Noise" (PNoise) test signal or you are in the Pause cycle of the Chirp test signal.	Wait until the pause has ended. Press the "Start" button.
		Non-supported Wave format.	Load a supported Wav-format.
		Cable not plugged in correctly.	Plug in the cable correctly.
Screen contrast poor.		Contrast needs to be adjusted.	Press "ESC" and operate the rotary switch to set the contrast.
MR-PRO: Wave files are not played back	"Mute" button lights up continuously.	Non-supported Wave format.	Load a supported Wave format.
MR-PRO indicates no impedance.	The lowest line is not displayed.	Output level too low. Incorrect test signal.	Increase the output level. Change to the SINEWAVE test signal.

10. Further Information

My NTi Audio

Register your instruments at My NTi Audio and benefit from the following possibilities:

- Free updates for your instruments
- Activation of optional product functions
- Premium access to downloads
- Receive application and product news
- Faster worldwide support
- Tracing support in case of loss or theft
- Calibration support

How to Register

- Open the web page "<https://my.nti-audio.com>".
- You are prompted to login or create your My NTi Audio account.
- The web page "My NTi Audio Products" opens.
- Select the product type and enter the serial number.
- Confirm with "Register".
- Now your product is listed in the table "My Products".



Congratulations, your NTi Audio product is registered.

Warranty Conditions

International warranty

NTi Audio guarantees the function of its products and the individual components for a period of one year from the date of sale. During this period, defective products will either be repaired free of charge or replaced.

Limitations

These guarantee provisions do not cover damage caused by accidents, transportation, incorrect use, carelessness, non-original accessories, the loss of parts, operation with non-specified input voltages, adapter types or incorrectly inserted batteries. NTi Audio accepts no responsibility for subsequent damage of any kind. The warranty will be voided by carrying out repairs or services by third parties who are not part of an approved NTi Audio Service Centre.

Statutory Rights

Consumers may have legal (statutory) rights under applicable national laws relating to the sale of consumer products. This warranty does not affect your statutory rights. You may assert any legal rights you have at your sole discretion.

Calibration Certificate

Your NTi Audio instrument has been carefully tested during production and corresponds to the specifications listed in "Technical Data". Calibration certificates for new products are optional.

NTi Audio recommends annual calibration of the products after the purchase. The calibration provides documented and traceable measurement accuracy and confirms that your NTi Audio product meets or exceeds the published specifications. The calibration and adjustment procedures follow the documentation and traceability requirements of the standard EN ISO / IEC 17025.

For calibrations kindly follow the service guidelines at www.nti-audio.com/service.

Service and Repairs

If your product is not functioning correctly or is damaged, please contact the local NTi Audio partner for assistance. If the product needs to be returned for service, kindly follow the service guidelines at www.nti-audio.com/service.

Declaration of Conformity

CE / FCC Compliance Statement



We, the manufacturer NTi Audio AG, Im alten Riet 102, 9494 Schaan, Liechtenstein, do hereby declare that the Minirator MR2 and Minirator MR-PRO products, approved in 2007, comply with the following standards or other standard documents:

- EMC: 2014/30/EU
- Harmonized standards: EN 61326-1
- Directive 2011/65/EC on the restriction of the use of certain hazardous substances in electrical and electronic equipment (RoHS).
- Directive 2012/19/EU on waste electrical and electronic equipment (WEEE).

This declaration will become invalid if modifications to the instrument are carried out without the written approval of NTi Audio.

Date: 25. July 2019



Position: COO

Information for Disposal and Recycling



Dispose of your instrument in accordance with the valid legal environmentally regulations in your country.

Regulations for the European Union and other European countries with corresponding laws:

The instrument must not be disposed of in the household garbage. At the end of its service life, bring the instrument to a collecting point for electrical recycling in accordance with the legal regulations.

Other countries outside the EU:

Contact your respective authorities for waste disposal and follow their regulations.

11. Technical Data Minirator

		MR2	MR-PRO
Outputs		Balanced XLR, unbalanced RCA phantom power resistant	
Inputs		DC power supply, USB	DC power supply, USB XLR for cable test
Signal Wave Forms		Sine, Polarity Test Signal, Delay Test Signal, White Noise (crest factor, PAR* = 3.05 (9.7 dB), 5 Hz - 22 kHz), Pink Noise (crest factor, PAR* = 4.5 (13.1 dB), 5 Hz - 22 kHz), Gated Pink Noise (1 - 9 seconds), Wave File playback (MR-PRO)	
Default wav-files			Fast Pink Noise 1s (PAR* = 12.5 dB) Fast Pink Noise 4s (PAR* = 13.1 dB) NTI Audio STIPA
Wave File Format	Sampling frequency: Resolution: Output level:		48 kHz 16 Bit, Mono / Stereo 0 dBFS = 18 dBu (sine) acc. to EBU R68
Frequency Setting	Range: Increment: Accuracy:	10 Hz to 20 kHz in 1 digit steps 0.01%	
Stepped Sweep Function	Frequency range: Increment: Sweep speed:	freely selectable 1/1, 1/3, 1/6, 1/12 octave selectable 0.5 to 5 seconds	
Continuous Sweep (Chirp) Function	Frequency range: Increment: Chirp speed:	freely selectable Linear / Logarithmic 1 to 99 seconds per cycle	
Level Setting	Units: Increment:	dBu, dBV, V in 1 digit steps	dBu, dBV, V, dBFS, % in 1 digit steps (e.g. 0.1 dBu)

* PAR = peak-to-average ratio

		MR2	MR-PRO
Output Level Ranges	Sine, Sweep, Chirp White Noise Pink Noise Polarity, Delay Test	-80 dBu to +8 dBu -80 dBu to +0 dBu -80 dBu to -2 dBu -80 dBu to +6 dBu	-80 dBu to +18 dBu -80 dBu to +10 dBu -80 dBu to +8 dBu -80 dBu to +16 dBu
Flatness	RL ≥ 600 Ohm	±0.5 dB	±0.2 dB @ 10 Hz to 12 kHz -0.1 dB / +0.3 dB @ 12 kHz to 20 kHz
Accuracy @ 1kHz		±0.5 dB	±0.2 dB
THD+N	22 Hz to 22 kHz, average, @ 1 kHz, typical	-90 dB (0.0032%) @ 8 dBu, Noise floor typ. 25 µV	-96 dB (0.0016%) @ 18 dBu, Noise floor typ. 15 µV
Output Impedance		200 Ohm (balanced)	12.5 Ohm balanced, I _{max} = 10 mA
Impedance Measurement	Method: Measurement range: Accuracy:		Absolute value Z 4 Ohm to 50 kOhm (pin 2-3) 2 Ohm to 25 kOhm (pin 1-2 or 1-3) @ f = 30 Hz to 10 kHz (Sine) @ Level from -20 to +18 dBu ±10% or ±2Ohm (whatever is higher)
Power Calculation	Reference voltage		25 V, 35 V, 50 V, 70.7 V, 100 V, 140 V, 200 V
Phantom Voltage	Measurement range: Accuracy:		0 to 54 V ±3 % or ±0.5 V
USB Functionality		Firmware update	Firmware update Mass Storage Device
Flash Memory			512 MByte for storing wave files and configurations
Signal Balance Accuracy @ XLR-Output		≥ 99% @ 1 kHz for output levels above -20 dBu	
Display		Graphical, with back light	
Auto-Power-Off		10, 30, 60 minutes or OFF	
Batteries		3 x AA Alkaline dry cells or rechargeable equivalents	

	MR2	MR-PRO
Battery Life	0 dBu, no load, typical 14 hours	8 hours
Temperature Range	0° to 45° C (32° to 113° F)	
Humidity	< 90% relative humidity, non-condensing	
Protection Rating	IP51	
Dimensions (LxWxH)	147 x 74 x 41 mm	152 x 81 x 43 mm (incl. protective shock jacket)
Weight including Batteries	250 g (9 oz.)	310 g (11 oz.)

